

# DGST

## Mini slide

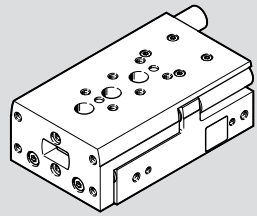

# FESTO

Festo SE & Co. KG  
Rüter Straße 82  
73734 Esslingen  
Deutschland  
+49 711 347-0

www.festo.com

Operating instructions

8159550  
2021-09d  
[8159552]



Translation of the original instructions

© 2021 all rights reserved to Festo SE & Co. KG

### 1 Applicable documents

All available documents for the product → [www.festo.com/sp](http://www.festo.com/sp).

Documents	Product	Table of contents
Operating instructions	Shock absorber DYSS-G8	-
Operating instructions	Shock absorber DYEFG8	-

Tab. 1

### 2 Safety

#### 2.1 Safety instructions

- Only use the product in its original condition without unauthorised modifications.
- Take into account the ambient conditions at the location of use.
- Observe the identifications on the product.
- Store the product in a cool, dry environment protected from UV and corrosion. Keep storage times short.
- Before working on the product, switch off the compressed air supply and lock it to prevent it from being switched on again.

#### 2.2 Intended use

The product is intended for the space-saving transport of masses. The product is approved for slide operating mode.

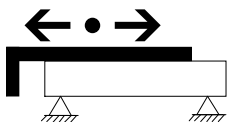

Fig.1

#### 2.3 Training of qualified personnel

Work on the product may only be carried out by qualified personnel who can evaluate the work and detect dangers. The qualified personnel have skills and experience in dealing with pneumatic (open-loop) control technology.

### 3 Additional information

- Contact the regional Festo contact if you have technical problems → [www.festo.com](http://www.festo.com).
- Accessories and spare parts → [www.festo.com/catalogue](http://www.festo.com/catalogue).

### 4 Function

The product is a non-rotating twin-piston drive with bearing guide. The slide is moved back and forth by alternate pressurisation of the supply ports. The slide is braked at the end position by shock absorbers.

### 5 Product design

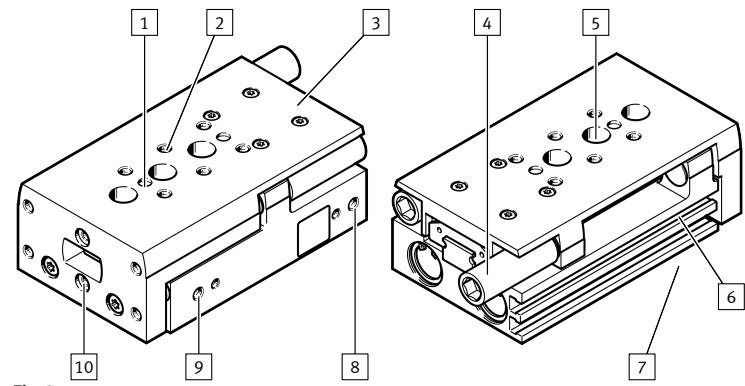

Fig.2

- |  |   |
|--|---|
| 1 Centring   | 6 Slot for proximity switch                                 |
| 2 Thread for mounting the payload                      | 7 Thread for mounting the mini slide (concealed underneath) |
| 3 Slide  | 8 Supply port (advance)                                     |
| 4 Shock absorber with threaded sleeve                  | 9 Supply port (retract)                                     |
| 5 Drilled holes for mounting the mini slide from above | 10 Thread with centring hole for mounting the payload       |

### 6 Transport

#### NOTICE

#### Unexpected and unbraked movement of components

- Secure moving components for transport.

1. Take product weight into account → 11 Technical data.
2. Maintain the support clearance of ≤ 300 mm when attaching transportation equipment.

### 7 Assembly

#### 7.1 Preparation

- Position the product to ensure that the operating elements are accessible, e.g. the clamping components for the shock absorbers.
  - Mount the product without torsional stresses.
  - Mount the product on a mounting surface with a flatness of 0.05% of the stroke length, but max. 0.1 mm.
  - If necessary: select the mounting components or the accessories. The centring sleeves are not included in the scope of delivery.
- To prevent collisions: mount the mounting components outside the positioning range.

#### 7.2 Mounting mini slide

1. Mount drive ensuring that the minimum number of screws is used.

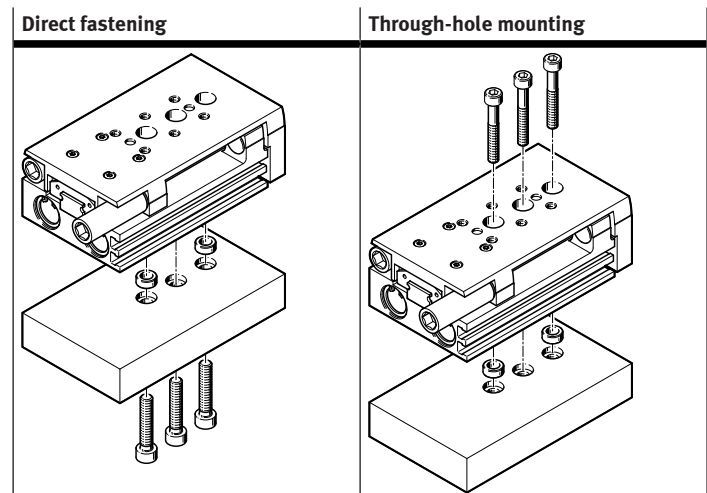

2. Tighten screws evenly.

DGST		-6	-8	-10	-12	-16	-20	-25	
Minimum number of screws dependent on the stroke									
10 ... 150	[mm]	2	2	2	2	2	2	2	
200	[mm]	-					3		
Direct fastening									
Screw		M4	M4	M5	M5	M6	M8	M8	
Centring [H7]	[mm]	5	5	7	7	9	12	12	
Through-hole mounting									
Screw		M3	M3	M4	M4	M5	M6	M6	
Centring [H7]	[mm]	5	5	7	7	9	12	12	

### 7.3 Mini slide attachment

- Mount the attachment on the slide or the yoke plate with screws and centring elements. Observe the maximum screw-in depth D.
- If necessary: select the mounting components or the accessories  
 → [www.festo.com/catalogue](http://www.festo.com/catalogue). The centring sleeves are not included in the scope of delivery.

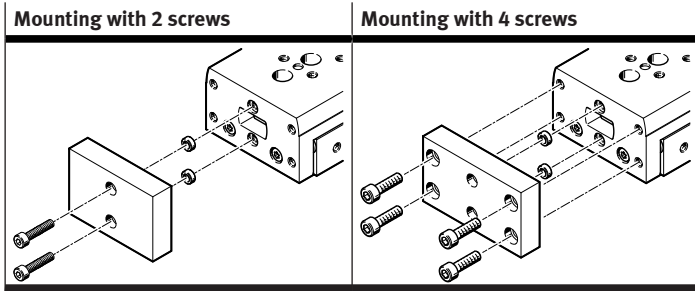

DGST	-6	-8	-10	-12	-16	-20	-25
<b>Mounting on the slide (top)</b>							
Screw	M3	M3	M4	M4	M5	M5	M6
Max. screw-in depth D [mm]	3.1	5.5	4.5	5.2	7.2	8	11
Centring [H7] [mm]	∅ 5	∅ 5	∅ 5	∅ 5	∅ 5	∅ 12	∅ 12
<b>Mounting on the slide with 2 screws (front)</b>							
Screw	–	M3	M3	M4	M4	M5	M6
Max. screw-in depth D [mm]	–	4.7	5.2	6.4	6.4	7.4	7.4
Centring [H7] [mm]	–	∅ 5	∅ 5	∅ 7	∅ 7	∅ 12	∅ 12
<b>Mounting on the slide with 4 screws (front)</b>							
Screw	M3	M3	M4	M4	M5	M5	M6
Max. screw-in depth D [mm]	4.5	4.5	6.5	6.5	8	8	10
Centring [H7] [mm]	∅ 2H8	∅ 5	∅ 5	∅ 7	∅ 7	∅ 12	∅ 12

### 7.4 Mounting the proximity switches

For position sensing with proximity switches:

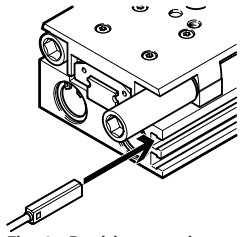

Fig. 3: Position sensing

- Slide the proximity switches into the slots → Fig. 3.
- Avoid external influence caused by magnetic or ferritic parts in the vicinity of the proximity switches. Check the required clearance for the specific application.
- To prevent contamination: use slot covers on all unused slots  
 → [www.festo.com/catalogue](http://www.festo.com/catalogue).

### 7.5 Mounting one-way flow control valves

To set the velocity:

- Use one-way flow control valves in the supply ports. They are screwed directly into the supply ports.

To secure the payload from dropping if the pressure fails:

- Use check valves.

## 8 Commissioning

### 8.1 Preparation

#### NOTICE

#### Unexpected movement of components.

- Keep foreign objects out of the positioning range.
- Initiate start-up at low speed.

- Slowly pressurise the complete system. Use the on-off valve HEL for slow start-up pressurisation.

With medium or large payloads or at high speeds:

- Use the sufficiently dimensioned arrester fixtures. Without the use of external arrester fixtures, the product will withstand the maximum speeds and payloads defined in the catalogue or the technical data.

### 8.2 Adjustment of slide end positions

In the factory settings for the mini slide DGST...-P/-Y12 the minimum distance L of the shock absorbers specified below for the slide end positions must be observed.

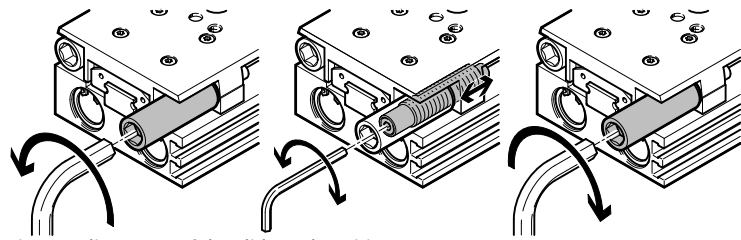
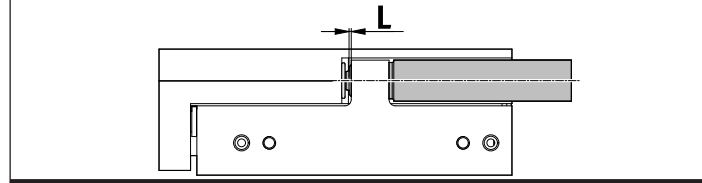

Fig. 4: Adjustment of the slide end positions

- Loosen the threaded sleeves.
- Position the slides one after the other at the retracted and advanced end positions.
- At the end position: screw in the shock absorber to the end position. Do not exceed the maximum torque when screwing the internal hexagon socket/slot. Maintain the minimum distance L. If the minimum distance L is not long enough, the shock absorbers will not be completely effective and the product will impact internally. This can lead to the destruction of the product.

DGST	-6	-8	-10	-12	-16	-20	-25
<b>Shock absorber</b>							
DYEF-G8-M...-Y1	4	5	6	8	10	12	14
DYEF-G8-M...-Y1F	4	5	6	8	10	–	–
DYEF-G8-S-M...	4	5	6	8	10	12	14
DYSS-G8-...	2	3	4	5	7	8	10
<b>Minimum distance L of the mini slide at retracted end position</b>							
DGST...-E-... [mm]	2.1	0.8	0.5	0.7	0.8	1	–
DGST...-P-... [mm]	3.1	2.7	2.6	–	–	–	–
DGST...-P1-... [mm]	–	–	–	–	–	2.9	3.1



DGST	-6	-8	-10	-12	-16	-20	-25
<b>Shock absorber</b>							
DYEF-G8-M...-Y1	4	5	6	8	10	12	14
DYEF-G8-M...-Y1F	4	5	6	8	10	–	–
DYEF-G8-S-M...	4	5	6	8	10	12	14
DYSS-G8-...	2	3	4	5	7	8	10
<b>Minimum distance L of the mini slides at extended end position</b>							
DGST...-E-... [mm]	1.05	1.1	1	–	–	–	1.2
DGST...-P-... [mm]	1.55	1.5	1.6	–	–	–	–
DGST...-P1-... [mm]	–	–	–	–	–	1.5	1.7

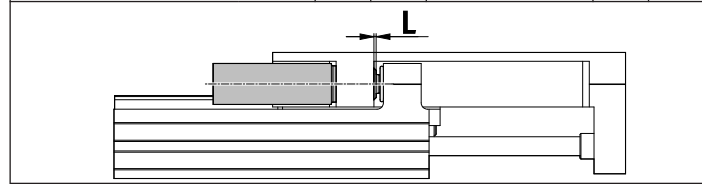

- At the end position: pressurise the slide as a counterhold to the shock absorber. Tighten the threaded sleeve to the specified tightening torque.

DGST	-6	-8	-10	-12	-16	-20	-25
<b>Shock absorber</b>							
DYEF-G8-M...-Y1	4	5	6	8	10	12	14
DYEF-G8-M...-Y1F	5	5	6	8	10	–	–
DYEF-G8-S-M...	4	5	6	8	10	12	14
DYSS-G8-...	2	3	4	5	7	8	10
<b>Internal hexagon/slot on the shock absorber</b>							
Max. torque [Nm]	0.1	0.5	0.6	1	3	5	10
<b>Threaded sleeve</b>							
Tightening torque [Nm]	0.4	0.64	0.8	1.6	2.4	4	6.4
Tolerance ± 20%							

#### NOTICE

The exact slide position must be checked during a test run with compressed air applied and, if necessary, corrected.

- When operating the DGST...-E1: restrict the speed.
- Observe the permissible impact energies → 11 Technical data.
- Suitable shock absorbers can be retrofitted to the product  
 → [www.festo.com/catalogue](http://www.festo.com/catalogue).

### 8.3 Test run

#### NOTICE

Risk of collision by payloads that protrude through the rotor/slide.

- Only turn adjusting screws while the rotor/slide is stationary.

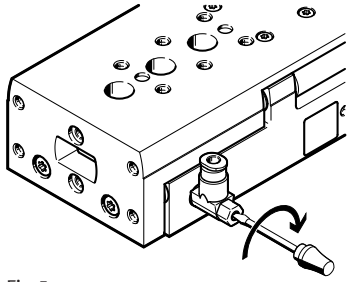

Fig.5

1. Fully close the one-way flow control valves on both sides, then open them one complete revolution.
2. Pressurise the drive on both sides simultaneously.
  - ↳ The slide moves slightly to a point of balance.
3. Then exhaust the drive on one side.
  - ↳ The slide moves to an end position.
4. Start the test run.
5. If needed: correct speed at the one-way flow control valves. The slide should reach the end positions without striking them harshly or recoiling.

### 9 Cleaning

Clean the product with a clean, soft cloth and non-abrasive cleaning agents.

For use with reduced particle emission:

- Remove abraded particles and soil from the product:
  - Prior to initial commissioning
  - Regularly during operation

### 10 Malfunctions

#### 10.1 Fault clearance

Fault description	Cause	Remedy
The slide moves unevenly.	The one-way flow control valves are not installed correctly.	Control the exhaust air flow.
The slide is in initial position despite pressurisation.	The tubing is faulty.	Check the tubing.
The slide speed is too low.	The air volume is insufficient.	<ul style="list-style-type: none"> <li>- Increase the connection cross-sections.</li> <li>- Check the flow control valve setting.</li> <li>- Connect a volume upstream.</li> </ul>
The slide stops in the end position without cushioning.	The speed is too high.	Reduce the speed.
	The cushioning is too low.	<ul style="list-style-type: none"> <li>- Re-adjust the shock absorber and the (fixed) stop → 8.1 Preparation.</li> <li>- Reduce the speed.</li> <li>- Check the shock absorbers and replace if necessary.</li> </ul>
	The air cushion is not present.	Pressurise both supply ports simultaneously, then exhaust one side.
	The shock absorbers are faulty.	Replace the shock absorbers.
	The payload is too large	Reduce the payload.

Tab. 2: Fault clearance

#### 10.2 Repair

Send the product to the Festo repair service for repair.

- Replacement of shock absorbers → 1 Applicable documents.

### 11 Technical data

DGST	-6	-8	-10	-12	-16	-20	-25
Design	Drive with scotch yoke system						
Guide	Recirculating ball bearing guide			Cage guide			
Mode of operation	double-acting						
Pneumatic connection	M3	M5					G1/8
Mounting position	any						
Ambient temperature	[°C]	-10 ... +60					
Cushioning							
DGST...-E1	Basic variant with internal, elastic cushioning without end position adjustment						
DGST...-E	Cushioning by external elastic shock absorbers DYE-F with end-position adjustment						
DGST...-P	Cushioning by external elastic shock absorbers DYE-F-G8 with end-position adjustment						
DGST...-P1							
DGST...-Y12	Cushioning by external hydraulic shock absorbers DYSS-G8 with end-position adjustment						

DGST	-6	-8	-10	-12	-16	-20	-25	
Max. velocity								
DGST...-E/-P	[m/s]	0.5	0.8					
DGST...-E1/-P1/-Y12	[m/s]	0.5						
Repetition accuracy								
DGST...-E/-P/-E1	[mm]	≤ 0.3						
DGST...-P1/-Y12	[mm]	≤ 0.02						
Operating conditions								
Operating medium	Compressed air to ISO 8573-1:2010 [7:4:4]							
Information on the operating medium	lubricated operation possible, in which case lubricated operation will always be required							
Operating pressure <sup>1)</sup>	[MPa]	0.15 ... 0.8		0.1 ... 0.8				
	[bar]	1.5 ... 8		1 ... 8				
	[psi]	22 ... 116		15 ... 116				
Theoretical force								
at 6 bar (advancing)	[N]	34	60	94	136	241	377	589
at 6 bar (return)	[N]	25	45	79	102	207	317	495
Impact energy in the end positions								
DGST...-E/-P	[J]	0.018	0.05	0.08	0.12	0.25	0.35	0.45
DGST...-E1	[J]	0.012	0.03	0.05	0.07	0.15	0.2	0.3
DGST...-P1	[J]	0.005	0.02	0.03	0.04	0.06	-	-
DGST...-Y12 (per stroke)	[J]	0.09	0.18	0.28	0.48	0.85	1.9	3.6
Max. operating frequency								
DGST...-Y12	[cycles/min]	50	80	80	80	70	50	50
Product weight								
DGST...-E1 with 10 mm stroke	[g]	90	129	247	391	454	978	1463
DGST...-E1 at max. stroke	[g]	172	310	561	988	1402	3275	4803
Materials								
Slide, housing	Anodised wrought aluminium alloy							
Piston rod	high-alloy stainless steel							
Guide	high-alloy steel, POM, TPE							
Seals	HNBR/PU							

1) With DGST-6/-8/-10/-12 the minimum operating pressure may increase slightly after downtime of > 24 h.

Tab. 3: Technical data DGST